

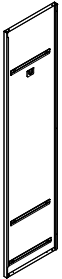





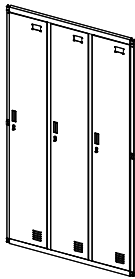
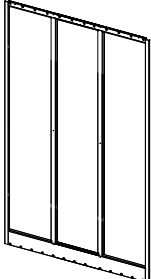

# ИНСТРУКЦИЯ ЗА МОНТАЖ НА МЕТАЛЕН ШКАФ СР-1295 J

					 Таван: 1 бр	 Дъно: 1 бр	 Тръби за закачалки: къса: 2 бр дълга: 1 бр	 Регулируеми крака: 4 бр
Лява страница: 1 бр	Дясна страница: 1 бр	Врата: 1 бр	Гръб: 1 бр	Разделител: 2 бр	 Рафт: ляв (малък): 4 бр десен (голям): 2 бр	 Винт 5x10: 33 бр	 Крака: 4 бр	

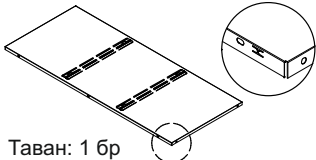
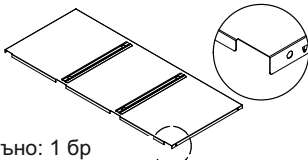
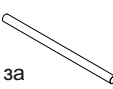

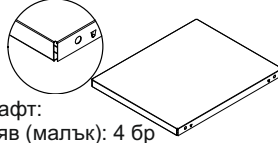
Вносител: "Бител" ЕООД  
гр. Пловдив, Тракия  
ул. "Нестор Абаджиев" 13  
ЕИК: 115163890  
Тел: +359 32 27 00 27  
www.bitel.bg

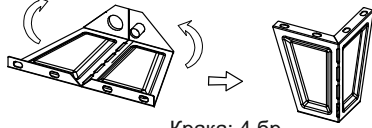
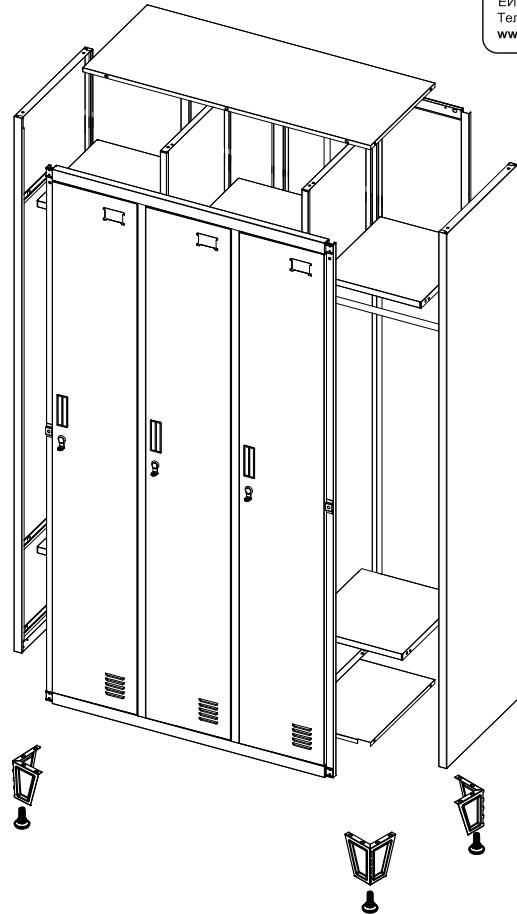
Максимално натоварване на рафт: 40 кг

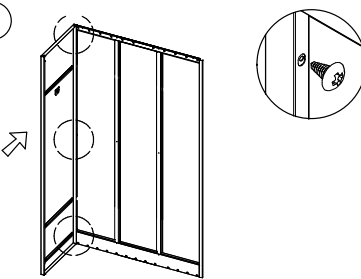
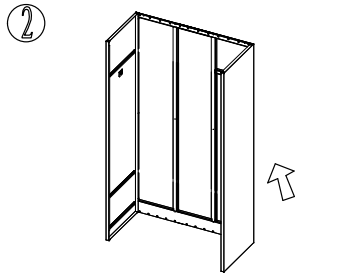
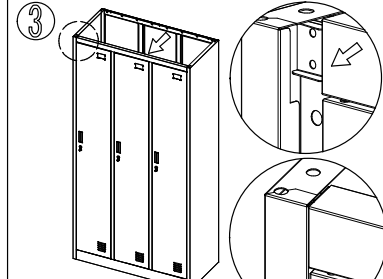
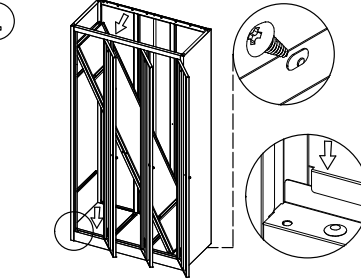
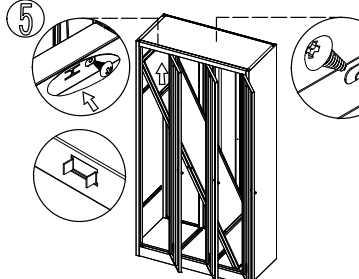
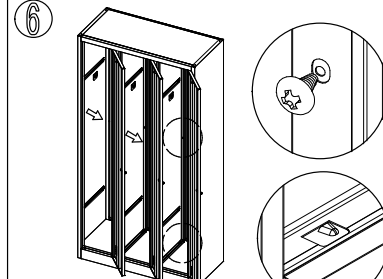
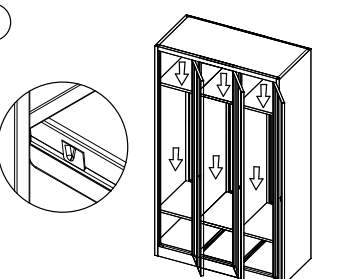
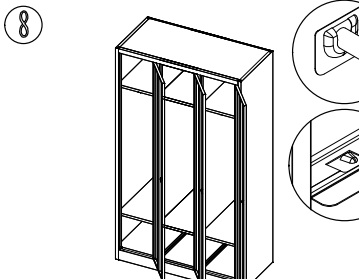
-   
Монтирайте лявата страница към гръба с помощта на винтовете.
-   
Монтирайте дясната страница към гръба с помощта на винтовете.
-   
Фиксирайте вратата към страниците.
-   
Монтирайте дъното и разделителите.
-   
Монтирайте тавана с помощта на винтовете.
-   
Монтирайте разделителите.
-   
Монтирайте рафтовете.
-   
Монтирайте тръбите за закачалки.

Монтирайте краката с помощта на винтовете и се уверете, че всички части са фиксирани.